

RFC: 1585

Network Working Group
Request for Comments: 1585
Category: Informational

J. Moy
Proteon, Inc.
March 1994

MOSPF: Analysis and Experience



Network Dictionary
<http://www.javvin.com/networkdictionary.html>



Network Protocols Map
<http://www.javvin.com/map.html>



Network Security Map
<http://www.javvin.com/securitymap.html>



Wireless Communications Technology Map
<http://www.javvin.com/wirelessmap.html>



Network Protocols Handbook
<http://www.javvin.com/model.html>



TCP/IP Quick Guide
<http://www.javvin.com/tcpipguide.html>



Ethernet Quick Guide
<http://www.javvin.com/ethernetguide.html>



Packet Analyzer
<http://www.javvin.com/packet.html>



DiskShare
<http://www.javvin.com/diskshare.html>



DiskAccess
<http://www.javvin.com/diskaccess.html>



LANsurveyor
<http://www.javvin.com/LANsurveyor.html>



CyberGauge
<http://www.javvin.com/CyberGauge.html>



Easy Network Service Monitor
<http://www.javvin.com/easy.html>



Business Card Scanner
<http://www.javvin.com/businesscard-scanner.html>



Color Cards and Picture Scanner
<http://www.javvin.com/colorcardscanner.html>



Portable Document Scanner
<http://www.javvin.com/portablescanner.html>



www.javvin.com



www.networkdictionary.com

Status of this Memo

This memo provides information for the Internet community. This memo does not specify an Internet standard of any kind. Distribution of this memo is unlimited.

Abstract

This memo documents how the MOSPF protocol satisfies the requirements imposed on Internet routing protocols by "Internet Engineering Task Force internet routing protocol standardization criteria" ([RFC 1264]).

Please send comments to mospf@gated.cornell.edu.



Network Dictionary

<http://www.javvin.com/networkdictionary.html>



Network Protocols Map

<http://www.javvin.com/map.html>



Network Security Map

<http://www.javvin.com/securitymap.html>



Wireless Communications Technology Map

<http://www.javvin.com/wirelessmap.html>



Network Protocols Handbook

<http://www.javvin.com/model.html>



TCP/IP Quick Guide

<http://www.javvin.com/tcpipguide.html>



Ethernet Quick Guide

<http://www.javvin.com/ethernetguide.html>



Packet Analyzer

<http://www.javvin.com/packet.html>



DiskShare

<http://www.javvin.com/diskshare.html>



DiskAccess

<http://www.javvin.com/diskaccess.html>



LANsurveyor

<http://www.javvin.com/LANsurveyor.html>



CyberGauge

<http://www.javvin.com/CyberGauge.html>



Easy Network Service Monitor

<http://www.javvin.com/easy.html>



Business Card Scanner

<http://www.javvin.com/businesscard-scanner.html>



Color Cards and Picture Scanner

<http://www.javvin.com/colorcardscanner.html>



Portable Document Scanner

<http://www.javvin.com/portablescanner.html>



www.javvin.com



www.networkdictionary.com

1. Summary of MOSPF features and algorithms

MOSPF is an enhancement of OSPF V2, enabling the routing of IP multicast datagrams. OSPF is a link-state (unicast) routing protocol, providing a database describing the Autonomous System's topology. IP multicast is an extension of LAN multicasting to a TCP/IP Internet. IP Multicast permits an IP host to send a single datagram (called an IP multicast datagram) that will be delivered to multiple destinations. IP multicast datagrams are identified as those packets whose destinations are class D IP addresses (i.e., addresses whose first byte lies in the range 224-239 inclusive). Each class D address defines a multicast group.

The extensions required of an IP host to participate in IP multicasting are specified in "Host extensions for IP multicasting" ([RFC 1112]). That document defines a protocol, the Internet Group Management Protocol (IGMP), that enables hosts to dynamically join and leave multicast groups.

MOSPF routers use the IGMP protocol to monitor multicast group membership on local LANs through the sending of IGMP Host Membership Queries and the reception of IGMP Host Membership Reports. A MOSPF router then distributes this group location information throughout the routing domain by flooding a new type of OSPF link state advertisement, the group-membership-LSA (type 6). This in turn enables the MOSPF routers to most efficiently forward a multicast datagram to its multiple destinations: each router calculates the path of the multicast datagram as a shortest-path tree whose root is the datagram source, and whose terminal branches are LANs containing group members.

A separate tree is built for each [source network, multicast destination] combination. To ease the computational demand on the routers, these trees are built "on demand", i.e., the first time a datagram having a particular combination of source network and multicast destination is received. The results of these "on demand" tree calculations are then cached for later use by subsequent matching datagrams.

MOSPF is meant to be used internal to a single Autonomous System. When supporting IP multicast over the entire Internet, MOSPF would have to be used in concert with an inter-AS multicast routing protocol (something like DVMRP would work).

The MOSPF protocol is based on the work of Steve Deering in [Deering]. The MOSPF specification is documented in [MOSPF].

1.1. Characteristics of the multicast datagram's path

As a multicast datagram is forwarded along its shortest-path tree, the datagram is delivered to each member of the destination multicast group. In MOSPF, the forwarding of the multicast datagram has the following properties:

- o The path taken by a multicast datagram depends both on the datagram's source and its multicast destination. Called source/destination routing, this is in contrast to most unicast datagram forwarding algorithms (like OSPF) that route based solely on destination.
- o The path taken between the datagram's source and any particular destination group member is the least cost path available. Cost is expressed in terms of the OSPF link-state metric.
- o MOSPF takes advantage of any commonality of least cost paths to destination group members. However, when members of the multicast group are spread out over multiple networks, the multicast datagram must at times be replicated. This replication is performed as few times as possible (at the tree branches), taking maximum advantage of common path segments.
- o For a given multicast datagram, all routers calculate an identical shortest-path tree. This is possible since the shortest-path tree is rooted at the datagram source, instead of being rooted at the calculating router (as is done in the unicast case). Tie-breakers have been defined to ensure that, when several equal-cost paths exist, all routers agree on which single path to use. As a result, there is a single path between the datagram's source and any particular destination group member. This means that, unlike OSPF's treatment of regular (unicast) IP data traffic, there is no provision for equal-cost multipath.
- o While MOSPF optimizes the path to any given group member, it does not necessarily optimize the use of the internetwork as a whole. To do so, instead of calculating source-based shortest-path trees, something similar to a minimal spanning tree (containing only the group members) would need to be calculated. This type of minimal spanning tree is called a Steiner tree in the literature. For a comparison of shortest-path tree routing to routing using Steiner trees, see [Deering2] and [Bharath-Kumar].
- o When forwarding a multicast datagram, MOSPF conforms to the link-layer encapsulation standards



Network Dictionary

<http://www.javvin.com/networkdictionary.html>



Network Protocols Map

<http://www.javvin.com/map.html>



Network Security Map

<http://www.javvin.com/securitymap.html>



Wireless Communications Technology Map

<http://www.javvin.com/wirelessmap.html>



Network Protocols Handbook

<http://www.javvin.com/model.html>



TCP/IP Quick Guide

<http://www.javvin.com/tcpipguide.html>



Ethernet Quick Guide

<http://www.javvin.com/ethernetguide.html>



Packet Analyzer

<http://www.javvin.com/packet.html>



DiskShare

<http://www.javvin.com/diskshare.html>



DiskAccess

<http://www.javvin.com/diskaccess.html>



LANsurveyor

<http://www.javvin.com/LANsurveyor.html>



CyberGauge

<http://www.javvin.com/CyberGauge.html>



Easy Network Service Monitor

<http://www.javvin.com/easy.html>



Business Card Scanner

<http://www.javvin.com/businesscard-scanner.html>



Color Cards and Picture Scanner

<http://www.javvin.com/colorcardscanner.html>



Portable Document Scanner

<http://www.javvin.com/portablescanner.html>



www.javvin.com



www.networkdictionary.com

for IP multicast datagrams as specified in "Host extensions for IP multicasting" ([RFC 1112]), "Transmission of IP datagrams over the SMDS Service" ([RFC 1209]) and "Transmission of IP and ARP over FDDI Networks" ([RFC 1390]). In particular, for ethernet and FDDI the explicit mapping between IP multicast addresses and data-link multicast addresses is used.

1.2. Miscellaneous features

This section lists, in no particular order, the other miscellaneous features that the MOSPF protocol supports:

o MOSPF routers can be mixed within an Autonomous System (and even within a single OSPF area) with non-multicast OSPF routers. When this is done, all routers will interoperate in the routing of unicasts. Unicast routing will not be affected by this mixing; all unicast paths will be the same as before the introduction of multicast. This mixing of multicast and non-multicast routers enables phased introduction of a multicast capability into an internetwork. However, it should be noted that some configurations of MOSPF and non-MOSPF routers may produce unexpected failures in multicast routing (see Section 6.1 of [MOSPF]).

o MOSPF does not include the ability to tunnel multicast datagrams through non-multicast routers. A tunneling capability has proved valuable when used by the DVMRP protocol in the MBONE. However, it is assumed that, since MOSPF is an intra-AS protocol, multicast can be turned on in enough of the Autonomous System's routers to achieve the required connectivity without resorting to tunneling. The more centralized control that exists in most Autonomous Systems, when compared to the Internet as a whole, should make this possible.

o In addition to calculating a separate datagram path for each [source network, multicast destination] combination, MOSPF can also vary the path based on IP Type of Service (TOS). As with OSPF unicast routing, TOS-based multicast routing is optional, and routers supporting it can be freely mixed with those that don't.

o MOSPF supports all network types that are supported by the base OSPF protocol: broadcast networks, point-to-points networks and non-broadcast multi-access (NBMA) networks. Note however that IGMP is not defined on NBMA networks, so while these networks can support the forwarding of multicast datagrams, they cannot support directly connected group members.

o MOSPF supports all Autonomous System configurations that are supported by the base OSPF protocol. In particular, an algorithm for forwarding multicast datagrams between OSPF areas is included. Also, areas with configured virtual links can be used for transit multicast traffic.

o A way of forwarding multicast datagrams across Autonomous System boundaries has been defined. This means that a multicast datagram having an external source can still be forwarded throughout the Autonomous System. Facilities also exist for forwarding locally generated datagrams to Autonomous System exit points, from which they can be further distributed. The effectiveness of this support will depend upon the nature of the inter-AS multicast routing protocol. The one assumption that has been made is that the inter-AS multicast routing protocol will operate in an reverse path forwarding (RPF) fashion: namely, that multicast datagrams originating from an external source will enter the Autonomous System at the same place that unicast datagrams destined for that source will exit.

o To deal with the fact that the external unicast and multicast topologies will be different for some time to come, a way to indicate that a route is available for multicast but not unicast (or vice versa) has been defined. This for example would allow a MOSPF system to use DVMRP as its inter-AS multicast routing protocol, while using BGP as its inter-AS unicast routing protocol.

o For those physical networks that have been assigned multiple IP network/subnet numbers, multicast routing can be disabled on all but one OSPF interface to the physical network. This avoids unwanted replication of multicast datagrams.

o For those networks residing on Autonomous System boundaries, which may be running multiple multicast routing protocols (or multiple copies of the same multicast routing protocol), MOSPF can be configured to encapsulate multicast datagrams with unicast (rather than multicast) link-level destinations. This also avoids unwanted replication of multicast datagrams.

o MOSPF provides an optimization for IP multicast's "expanding ring search" (sometimes called "TTL scoping") procedure. In an expanding ring search, an application finds the nearest server by sending out successive multicasts, each with a larger TTL. The first responding server will then be the closest (in terms of hops, but not necessarily in terms of the OSPF metric). MOSPF minimizes the network



Network Dictionary

<http://www.javvin.com/networkdictionary.html>



Network Protocols Map

<http://www.javvin.com/map.html>



Network Security Map

<http://www.javvin.com/securitymap.html>



Wireless Communications Technology Map

<http://www.javvin.com/wirelessmap.html>



Network Protocols Handbook

<http://www.javvin.com/model.html>



TCP/IP Quick Guide

<http://www.javvin.com/tcpiguide.html>



Ethernet Quick Guide

<http://www.javvin.com/ethernetguide.html>



Packet Analyzer

<http://www.javvin.com/packet.html>



DiskShare

<http://www.javvin.com/diskshare.html>



DiskAccess

<http://www.javvin.com/diskaccess.html>



LANsurveyor

<http://www.javvin.com/LANsurveyor.html>



CyberGauge

<http://www.javvin.com/CyberGauge.html>



Easy Network Service Monitor

<http://www.javvin.com/easy.html>



Business Card Scanner

<http://www.javvin.com/businesscard-scanner.html>



Color Cards and Picture Scanner

<http://www.javvin.com/colorcardscanner.html>



Portable Document Scanner

<http://www.javvin.com/portablescanner.html>



www.javvin.com



www.networkdictionary.com

bandwidth consumed by an expanding ring search by refusing to forward multicast datagrams whose TTL is too small to ever reach a group member.

2. Security architecture

All MOSPF protocol packet exchanges (excluding IGMP) are specified by the base OSPF protocol, and as such are authenticated. For a discussion of OSPF's authentication mechanism, see Appendix D of [OSPF].

3. MIB support

Management support for MOSPF has been added to the base OSPF V2 MIB [OSPF MIB]. These additions consist of the ability to read and write the configuration parameters specified in Section B of [MOSPF], together with the ability to dump the new group-membership-LSAs.

4. Implementations

There is currently one MOSPF implementation, written by Proteon, Inc. It was released for general use in April 1992. It is a full MOSPF implementation, with the exception of TOS-based multicast routing. It also does not contain an inter-AS multicast routing protocol.

The multicast applications included with the Proteon MOSPF implementation include: a multicast pinger, console commands so that the router itself can join and leave multicast groups (and so respond to multicast pings), and the ability to send SNMP traps to a multicast address. Proteon is also using IP multicast to support the tunneling of other protocols over IP. For example, source route bridging is tunneled over a MOSPF domain, using one IP multicast address for explorer frames and mapping the segment/bridge found in a specifically-routed frame's RIF field to other IP multicast addresses. This last application has proved popular, since it provides a lightweight transport that is resistant to reordering.

The Proteon MOSPF implementation is currently running in approximately a dozen sites, each site consisting of 10-20 routers.

Table 1 gives a comparison between the code size of Proteon's base OSPF implementation and its MOSPF implementation. Two dimensions of

	lines of C	bytes of 68020 object code
OSPF base	11,693	63,160
MOSPF	15,247	81,956

Table 1: Comparison of OSPF and MOSPF code sizes

size are indicated: lines of C (comments and blanks included), and bytes of 68020 object code. In both cases, the multicast extensions to OSPF have engendered a 30% size increase.

Note that in these sizes, the code used to configure and monitor the implementation has been included. Also, in the MOSPF code size figure, the IGMP implementation has been included.

5. Testing

Figure 1 shows the topology that was used for the initial debugging of Proteon's MOSPF implementation. It consists of seven MOSPF routers, interconnected by ethernets, token rings, FDDIs and serial lines. The applications used to test the routing were multicast ping and the sending of traps to a multicast address (the box labeled "NAZ" was a network analyzer that was occasionally sending IGMP Host Membership Reports and then continuously receiving multicast SNMP traps). The "vat" application was also used on workstations (without running the DVMRP "mrouted" daemon; see "Distance Vector Multicast Routing Protocol", [RFC 1075]) which were multicasting packet voice across the MOSPF domain.

The MOSPF features tested in this setup were:

- o Re-routing in response to topology changes.
- o Path verification after altering costs.



Network Dictionary

<http://www.javvin.com/networkdictionary.html>



Network Protocols Map

<http://www.javvin.com/map.html>



Network Security Map

<http://www.javvin.com/securitymap.html>



Wireless Communications Technology Map

<http://www.javvin.com/wirelessmap.html>



Network Protocols Handbook

<http://www.javvin.com/model.html>



TCP/IP Quick Guide

<http://www.javvin.com/tcpipguide.html>



Ethernet Quick Guide

<http://www.javvin.com/ethernetguide.html>



Packet Analyzer

<http://www.javvin.com/packet.html>



DiskShare

<http://www.javvin.com/diskshare.html>



DiskAccess

<http://www.javvin.com/diskaccess.html>



LANsurveyor

<http://www.javvin.com/LANsurveyor.html>



CyberGauge

<http://www.javvin.com/CyberGauge.html>



Easy Network Service Monitor

<http://www.javvin.com/easy.html>



Business Card Scanner

<http://www.javvin.com/businesscardscanner.html>



Color Cards and Picture Scanner

<http://www.javvin.com/colorcardscanner.html>



Portable Document Scanner

<http://www.javvin.com/portablescanner.html>



www.javvin.com



www.networkdictionary.com

- o Routing multicast datagrams between areas.
- o Routing multicast datagrams to and from external addresses.
- o The various tiebreakers employed when constructing datagram shortest-path trees.
- o MOSPF over non-broadcast multi-access networks.
- o Interoperability of MOSPF and non-multicast OSPF routers.

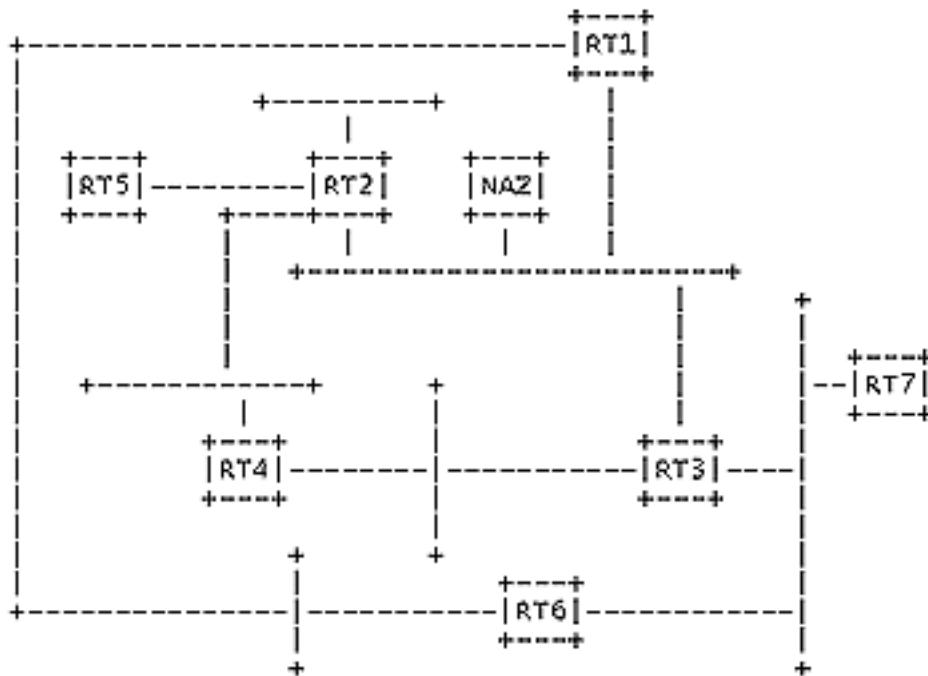

Figure 1: Initial MOSPF test setup

Due to the commercial tunneling applications developed by Proteon that use IP multicast, MOSPF has been deployed in a number of operational but non-Internet-connected sites. MOSPF has been also deployed in some Internet-connected sites (e.g., OARnet) for testing purposes. The desire of these sites is to use MOSPF to attach to the "mbone". However, an implementation of both MOSPF and DVMRP in the same box is needed; without this one way communication has been achieved (sort of like lecture mode in vat) by configuring multicast static routes in the MOSPF implementation. The problem is that there is no current way to inject the MOSPF source information into DVMRP.

The MOSPF features that have not yet been tested are:

- o The interaction between MOSPF and virtual links.
- o Interaction between MOSPF and other multicast routing protocols (e.g., DVMRP).
- o TOS-based routing in MOSPF.

6. A brief analysis of MOSPF scaling

MOSPF uses the Dijkstra algorithm to calculate the path of a multicast datagram through any given OSPF area. This calculation encompasses all the transit nodes (routers and networks) in the area; its cost scales as $O(N \cdot \log(N))$ where N is the number of transit nodes (same as the cost of the OSPF unicast intra-area routing calculation). This is the cost of a single path calculation; however, MOSPF calculates a separate path for each [source network, multicast destination, TOS] tuple. This is potentially a lot of Dijkstra calculations.

MOSPF proposes to deal with this calculation burden by calculating datagram paths in an "on demand" fashion. That is, the path is calculated only when receiving the first datagram in a stream. After the calculation, the results are cached for use by later matching datagrams. This on demand calculation alleviates the cost of the routing calculations in two ways: 1) It spreads the routing calculations out over time and 2) the



Network Dictionary

<http://www.javvin.com/networkdictionary.html>



Network Protocols Map

<http://www.javvin.com/map.html>



Network Security Map

<http://www.javvin.com/securitymap.html>



Wireless Communications Technology Map

<http://www.javvin.com/wirelessmap.html>



Network Protocols Handbook

<http://www.javvin.com/model.html>



TCP/IP Quick Guide

<http://www.javvin.com/tcpiguide.html>



Ethernet Quick Guide

<http://www.javvin.com/ethernetguide.html>



Packet Analyzer

<http://www.javvin.com/packet.html>



DiskShare

<http://www.javvin.com/diskshare.html>



DiskAccess

<http://www.javvin.com/diskaccess.html>



LANsurveyor

<http://www.javvin.com/LANsurveyor.html>



CyberGauge

<http://www.javvin.com/CyberGauge.html>



Easy Network Service Monitor

<http://www.javvin.com/easy.html>



Business Card Scanner

<http://www.javvin.com/businesscard-scanner.html>



Color Cards and Picture Scanner

<http://www.javvin.com/colorcardscanner.html>



Portable Document Scanner

<http://www.javvin.com/portablescanner.html>



www.javvin.com



www.networkdictionary.com

router does fewer calculations, since it does not even calculate the paths of datagrams whose path will not even touch the router.

Cache entries need never be timed out, although they are removed on topological changes. If an implementation chooses to limit the amount of memory consumed by the cache, probably by removing selected entries, care must be taken to ensure that cache thrashing does not occur.

The effectiveness of this "on demand" calculation will need to be proven over time, as multicast usage and traffic patterns become more evident.

As a simple example, suppose an OSPF area consists of 200 routers. Suppose each router represents a site, and each site is participating simultaneously with three other local sites (inside the area) in a video conference. This gives $200/4 = 50$ groups, and 200 separate datagram trees. Assuming each datagram tree goes through every router (which probably won't be true), each router will be doing 200 Dijkstras initially (and on internal topology changes). The time to run a 200 node Dijkstra on a 10 mips processor was estimated to be 15 milliseconds in "OSPF protocol analysis" ([RFC 1245]). So if all 200 Dijkstras need to be done at once, it will take 3 seconds total on a 10 mips processor. In contrast, assuming each video stream is 64Kb/sec, the routers will constantly forward 12Mb/sec of application data (the cost of this soon dwarfing the cost of the Dijkstras).

In this example there are also 200 group-membership-LSAs in the area; since each group membership-LSA is around 64 bytes, this adds $64*200 = 12K$ bytes to the OSPF link state database.

Other things to keep in mind when evaluating the cost of MOSPF's routing calculation are:

- o Assuming that the guidelines of "OSPF protocol analysis" ([RFC 1245]) are followed and areas are limited to 200 nodes, the cost of the Dijkstra will not grow unbounded, but will instead be capped at the Dijkstra for 200 nodes. One need then worry about the number of Dijkstras, which is determined by the number of [datagram source, multicast destination] combinations.

- o A datagram whose destination has no group members in the domain can still be forwarded through the MOSPF system. However, the Dijkstra calculation here depends only on the [datagram source, TOS], since the datagram will be forwarded along to "wild-card receivers" only. Since the number of group members in a 200 router area is probably also bounded, the possibility of unbounded calculation growth lies in the number of possible datagram sources. (However, it should be noted that some future multicast applications, such as distributed computing, may generate a large number of short-lived multicast groups).

- o By collapsing routing information before importing it into the area/AS, the number of sources can be reduced dramatically. In particular, if the AS relies on a default external route, most external sources will be covered by a single Dijkstra calculation (the one using 0.0.0.0 as the source).

One other factor to be considered in MOSPF scaling is how often cache entries need to be recalculated, as a result of a network topology change. The rules for MOSPF cache maintenance are explained in Section 13 of [MOSPF]. Note that the further away the topology change happens from the calculating router, the fewer cache entries need to be recalculated. For example, if an external route changes, many fewer cache entries need to be purged as compared to a change in a MOSPF domain's internal link. For scaling purposes, this is exactly the desired behavior. Note that "OSPF protocol analysis" ([RFC 1245]) bears this out when it shows that changes in external routes (on the order of once a minute for the networks surveyed) are much more frequent than internal changes (between 15 and 50 minutes for the networks surveyed).

7. Known difficulties

The following are known difficulties with the MOSPF protocol:

- o When a MOSPF router itself contains multicast applications, the choice of its application datagrams' source addresses should be made with care. Due to OSPF's representation of serial lines, using a serial line interface address as source can lead to excess data traffic on the serial line. In fact, using any interface address as source can lead to excess traffic, owing to MOSPF's decision to always multicast the packet onto the source network as part of the forwarding process (see Section 11.3 of [MOSPF]). However, optimal behavior can be achieved by assigning the router an interface-independent address, and using this as the datagram source.

This concern does not apply to regular IP hosts (i.e., those that are not MOSPF routers).

- o It is necessary to ensure, when mixing MOSPF and non-multicast routers on a LAN, that a MOSPF



Network Dictionary

<http://www.javvin.com/networkdictionary.html>



Network Protocols Map

<http://www.javvin.com/map.html>



Network Security Map

<http://www.javvin.com/securitymap.html>



Wireless Communications Technology Map

<http://www.javvin.com/wirelessmap.html>



Network Protocols Handbook

<http://www.javvin.com/model.html>



TCP/IP Quick Guide

<http://www.javvin.com/tcpiguide.html>



Ethernet Quick Guide

<http://www.javvin.com/ethernetguide.html>

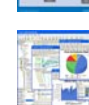

Packet Analyzer

<http://www.javvin.com/packet.html>



DiskShare

<http://www.javvin.com/diskshare.html>



DiskAccess

<http://www.javvin.com/diskaccess.html>



LANsurveyor

<http://www.javvin.com/LANsurveyor.html>



CyberGauge

<http://www.javvin.com/CyberGauge.html>



Easy Network Service Monitor

<http://www.javvin.com/easy.html>



Business Card Scanner

<http://www.javvin.com/businesscard-scanner.html>



Color Cards and Picture Scanner

<http://www.javvin.com/colorcardscanner.html>



Portable Document Scanner

<http://www.javvin.com/portablescanner.html>



www.javvin.com



www.networkdictionary.com

router becomes Designated Router. Otherwise multicast datagrams will not be forwarded on the LAN, nor will group membership be monitored on the LAN, nor will the group-membership-LSAs be flooded over the LAN. This can be an operational nuisance, since OSPF's Designated Router election algorithm is designed to discourage Designated Router transitions, rather than to guarantee that certain routers become Designated Router. However, assigning a DR Priority of 0 to all non-multicast routers will always guarantee that a MOSPF router is selected as Designated Router.

8. Future work

In the future, it is expected that the following work will be done on the MOSPF protocol:

- o More analysis of multicast traffic patterns needs to be done, in order to see whether the MOSPF routing calculations will pose an undue processing burden on multicast routers. If necessary, further ways to ease this burden may need to be defined. One suggestion that has been made is to revert to reverse path forwarding when the router is unable to calculate the detailed MOSPF forwarding cache entries.

- o Experience needs to be gained with the interactions between multiple multicast routing algorithms (e.g., MOSPF and DVMRP).

- o Additional MIB support for the retrieval of forwarding cache entries, along the lines of the "IP forwarding table MIB" ([RFC 1354]), would be useful.

9. References

- [Bharath-Kumar] Bharath-Kumar, K., and J. Jaffe, "Routing to multiple destinations in Computer Networks", IEEE Transactions on Communications, COM-31[3], March 1983.
- [Deering] Deering, S., "Multicast Routing in Internetworks and Extended LANs", SIGCOMM Summer 1988 Proceedings, August 1988.
- [Deering2] Deering, S., "Multicast Routing in a Datagram Internetwork", Stanford Technical Report STAN-CS-92-1415, Department of Computer Science, Stanford University, December 1991.
- [OSPF] Moy, J., "OSPF Version 2", RFC 1583, Proteon, Inc., March 1994.
- [OSPF MIB] Baker F., and R. Coltun, "OSPF Version 2 Management Information Base", RFC 1253, ACC, Computer Science Center, August 1991.
- [MOSPF] Moy, J., "Multicast Extensions to OSPF", RFC 1584, Proteon, Inc., March 1994.
- [RFC 1075] Waitzman, D., Partridge, C. and S. Deering, "Distance Vector Multicast Routing Protocol", RFC 1075, BBN STC, Stanford University, November 1988.
- [RFC 1112] Deering, S., "Host Extensions for IP Multicasting", Stanford University, RFC 1112, May 1988.
- [RFC 1209] Piscitello, D., and J. Lawrence, "Transmission of IP Datagrams over the SMDS Service", RFC 1209, Bell Communications Research, March 1991.
- [RFC 1245] Moy, J., Editor, "OSPF Protocol Analysis", RFC 1245, Proteon, Inc., July 1991.
- [RFC 1246] Moy, J., Editor, "Experience with the OSPF Protocol", RFC 1245, Proteon, Inc., July 1991.
- [RFC 1264] Hinden, R., "Internet Routing Protocol



Network Dictionary

<http://www.javvin.com/networkdictionary.html>



Network Protocols Map

<http://www.javvin.com/map.html>



Network Security Map

<http://www.javvin.com/securitymap.html>



Wireless Communications Technology Map

<http://www.javvin.com/wirelessmap.html>



Network Protocols Handbook

<http://www.javvin.com/model.html>



TCP/IP Quick Guide

<http://www.javvin.com/tcpiguide.html>



Ethernet Quick Guide

<http://www.javvin.com/ethernetguide.html>



Packet Analyzer

<http://www.javvin.com/packet.html>



DiskShare

<http://www.javvin.com/diskshare.html>



DiskAccess

<http://www.javvin.com/diskaccess.html>



LANsurveyor

<http://www.javvin.com/LANsurveyor.html>



CyberGauge

<http://www.javvin.com/CyberGauge.html>



Easy Network Service Monitor

<http://www.javvin.com/easy.html>



Business Card Scanner

<http://www.javvin.com/businesscard-scanner.html>



Color Cards and Picture Scanner

<http://www.javvin.com/colorcardscanner.html>



Portable Document Scanner

<http://www.javvin.com/portablescanner.html>



www.javvin.com



www.networkdictionary.com

Standardization Criteria", RFC 1264, BBN, October 1991.

[RFC 1390] Katz, D., "Transmission of IP and ARP over FDDI Networks", RFC 1390, cisco Systems, Inc., January 1993.

[RFC 1354] Baker, F., "IP Forwarding Table MIB", RFC 1354, ACC, July 1992.

Security Considerations

Security issues are not discussed in this memo, tho see Section 2.

Author's Address

John Moy
Proteon, Inc.
9 Technology Drive
Westborough, MA 01581

Phone: (508) 898-2800
EMail: jmoy@proteon.com



Network Dictionary

<http://www.javvin.com/networkdictionary.html>



Network Protocols Map

<http://www.javvin.com/map.html>



Network Security Map

<http://www.javvin.com/securitymap.html>



Wireless Communications Technology Map

<http://www.javvin.com/wirelessmap.html>



Network Protocols Handbook

<http://www.javvin.com/model.html>



TCP/IP Quick Guide

<http://www.javvin.com/tcpipguide.html>



Ethernet Quick Guide

<http://www.javvin.com/ethernetguide.html>



Packet Analyzer

<http://www.javvin.com/packet.html>



DiskShare

<http://www.javvin.com/diskshare.html>



DiskAccess

<http://www.javvin.com/diskaccess.html>



LANsurveyor

<http://www.javvin.com/LANsurveyor.html>



CyberGauge

<http://www.javvin.com/CyberGauge.html>



Easy Network Service Monitor

<http://www.javvin.com/easy.html>



Business Card Scanner

<http://www.javvin.com/businesscard-scanner.html>



Color Cards and Picture Scanner

<http://www.javvin.com/colorcardscanner.html>



Portable Document Scanner

<http://www.javvin.com/portablescanner.html>



www.javvin.com



www.networkdictionary.com